

Member of the BPW Group



LED WARNING LIGHT

Slim design and extremely durable



LED Warning strobe light

Flashing lights - two variants

- Slim-Line warning light with 3 or 6 LED's
- Compact and robust design
- 10 flash patterns – flash colour amber
- Flat surface installation or integrable from behind
- Lens and bezel of impact resistant polycarbonate

- Housing of aluminium
- Open end or Super Seal connection
- Multi voltage 10-32V
- Certified for special transport vehicles XA1
- ADR approved



Pos. 1



Pos. 2

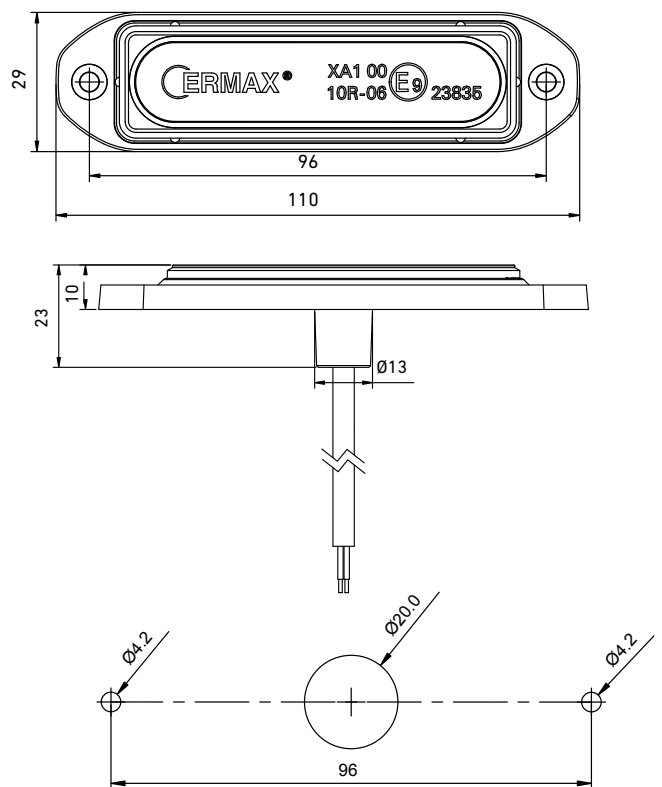
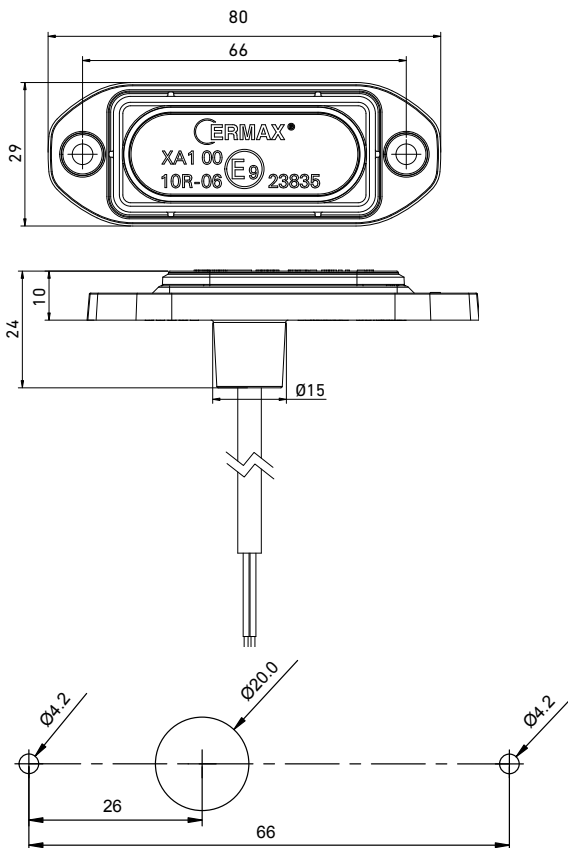

LED Warning light 12/24V

Technical details

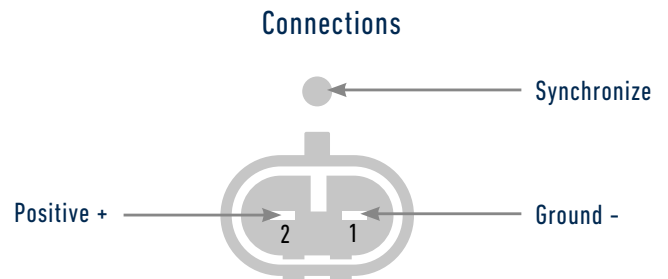
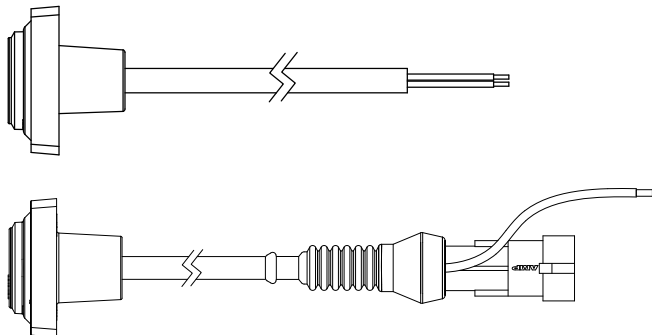

Selection of flash pattern

Briefly connect (0.5 - 2 sec) the green wire to +, to change the flash pattern.

If the green wire is connected to + more than 5 sec, the flash pattern resets to flash pattern 1.

Synchronization

In order to synchronize multiple individual lights, all lights must be set to the same flash pattern and be connected with the green wire.

Pin	Connection	
Pin 2	Positive +	Red
Pin 1	Ground -	White
-	Synchronization	Green

Assembly instruction

Can be found at www.ermasonline.dk

Description

Lens/Bezel: Polycarbonate
 Housing: Aluminium
 Flash colour: Amber
 Flash pattern: 10
 Mounting: Screw \varnothing 4 mm
 Working temperature: -40°C - $+60^{\circ}\text{C}$
 IP Rating: IP69K

3 YEAR WARRANTY (E) ECE R65 EMC XA1

Voltage	Cable length	Connection	Consumption	Dimension L x H x D	Bolt distance	Light source	Flash pattern	Pos	Artikel no.
12/24V	2500 mm	Open end	6,3W	80 x 29 x 10 mm	66 mm	3 x LED	10	1	098 286 430
12/24V	300 mm	Super Seal socket	6,3W	80 x 29 x 10 mm	66 mm	3 x LED	10	1	098 286 435
12/24V	2500 mm	Open end	17W	110 x 29 x 10 mm	96 mm	6 x LED	10	2	098 286 460
12/24V	300 mm	Super Seal socket	17W	110 x 29 x 10 mm	96 mm	6 x LED	10	2	098 286 465

Brands of the BPW Group::



February 2024 • Version 1.0



ERMAX A/S
Vranderupvej 2 • DK-6000 Kolding
Tel. +45 3969 6800 • www.ermax.dk